





Application	Medium voltage straight splice for polymeric cables
Standard	IEEE404
Voltage class	15, 25 kV
Cable range 15kV	1/0 AWG - 500 kcmil (indicative)
Cable range 25kV	1/0 AWG - 4/0 AWG (indicative)
Conductor material	Aluminum, copper
Conductor type	Round solid, round stranded, round stranded compact
Insulation O.D. range	0.75" - 1.26"
Cable jacket O.D. range	0.95" - 2"



Important Disclaimer Notice: All statements, technical information, and recommendations related to Lovink Energetech's products products are based on information believed to be sound but Lovink Energetech can in no way guarantee the accuracy or completeness of the installation guide. It is merely a recommendation of good practice. This installation guide should only be used by certified, fully qualified electricians and not be used or in any way relied upon without consultation with and supervision of experienced construction personnel, engineers, or network design specialists. If further information is required, Lovink Energetech should be consulted. Lovink Energetech does not warrant that this installation guide is error free, nor does Lovink Energetech warrant the suitability, fitness or otherwise of this installation guide for any stated or implied purposes expressed or implied in this installation guide or other documents. LOVINK DISCLAIMS ANY WARRANTIES, INCLUDING WITHOUT LIMITATION IMPLIED WARRANTIES OF MERCHANTABILITY OR FITNESS FOR PURPOSE. In no event will Lovink Energetech be liable to the user of this installation guide in contract, in tort (including negligence), strict liability, or other legal theory for any special, indirect, incidental or consequential damage or loss whatsoever, including but not limited to damage or loss of use of equipment, plant or power system, cost of capital, loss of power, additional expenses in the use of existing power facilities, or claims against the user by its customers resulting from the use of the information, recommendations and descriptions contained in this installation guide. Lovink Energetech reserves the right to modify the contents of this publication or remove parts at any time without having to give notice.

General remarks

-  Follow any **safety instructions** issued by the network administrator and/or your employer!
-  Make sure the connection stays **dry and clean** all through the assembly!
-  This instruction is meant as a guideline for **trained and certified splicers**. Knowledge of medium voltage technology and experience in cable preparation should be present!

1 Cable preparation

⚠ Always clean jacket of each cable end for at least 20"

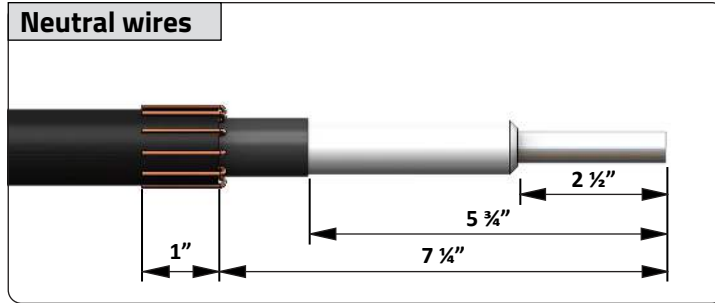

⚠ Bevel edge on insulation layer (XLPE/EPR)

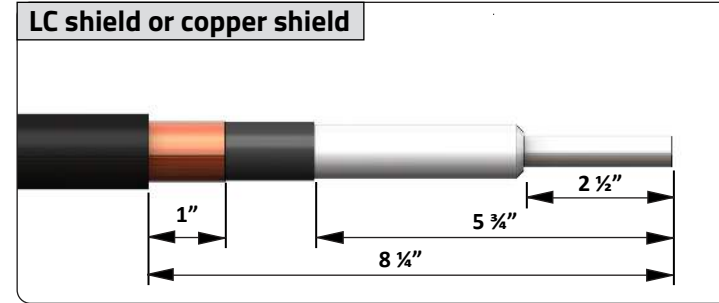

2 Splice body and connector

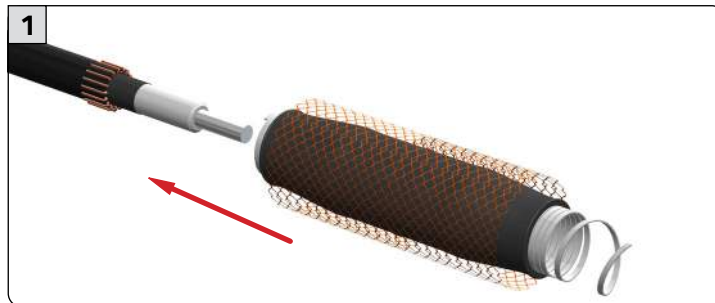

Pre-park the splice body and neutral sleeve onto a cable end.

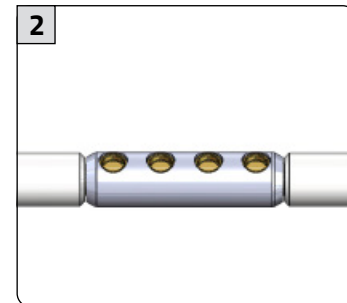

Fit the connector according to the instruction supplied with the connector.

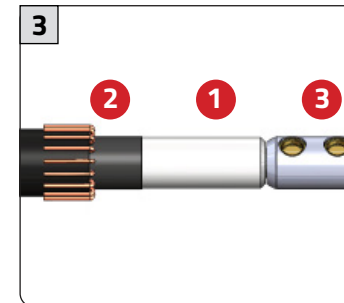

Clean the cable insulation first, second the semi-con layer and connector with a Lovink wet cleaning tissue.

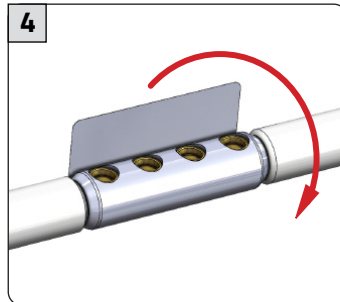

Cover the holes of the connector with the aluminum tape pad.

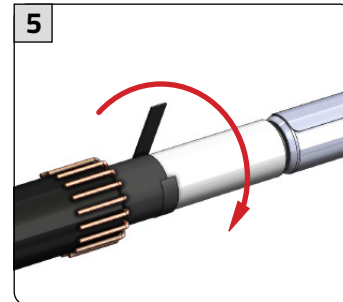

OPTIONAL - In case of a step transition in easy-peel semicon; wrap the transition with void filling tape.

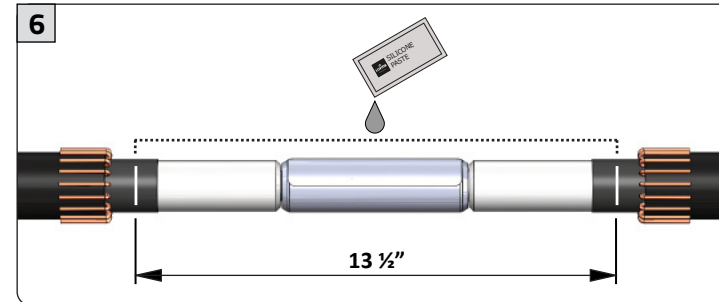

Mark the area to lubricate. Lubricate the cables and connector between the markings with Lovink silicone paste.

3 Assembly of splice body and neutral



Position the splice body over the cable and connector.

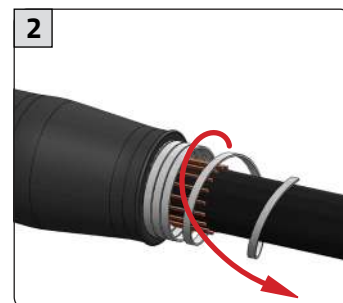

Remove the spiral from the splice body by pulling and unwinding the spiral cord counter-clockwise.

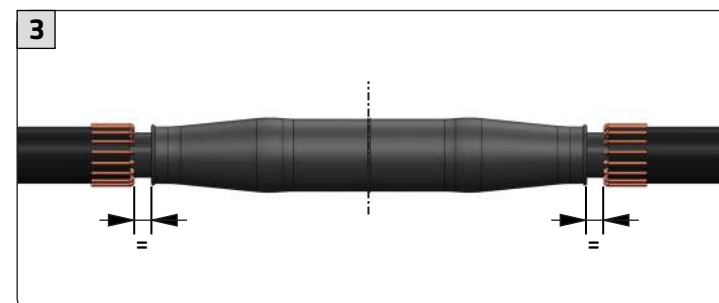

Check if the splice body is centralized relative to the cable assembly, adjust if necessary. Remove the spiral from the cable and clean the cable jacket with a wet cleaning tissue.

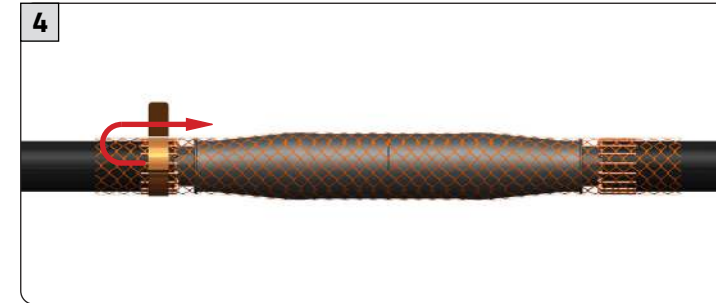

Position and stretch the neutral sleeve. Connect the sleeve onto the cable neutral using constant force springs. Bend excess sleeve back toward the centre. Be sure to have the neutral sleeve tight around the body.

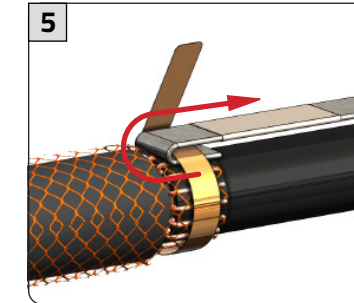

OPTIONAL - In case of locally connected neutral, fold the copper braid into one of the constant force springs. Make sure the solder block is inside the splice.

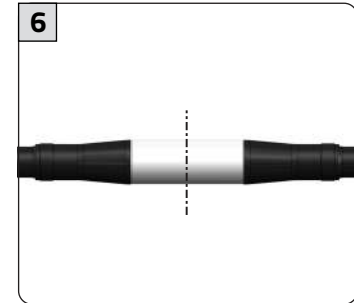

Wrap the foam pad tightly around the splice body. Wrap both constant force springs with PiB tape, one overlap layer onto the foam pad.

4 Assembly of outer shells and Protolin® filling

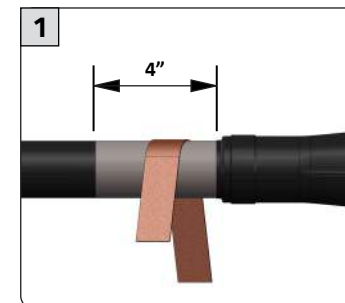

Abrade the cable jacket with sand paper for 4" on both ends.

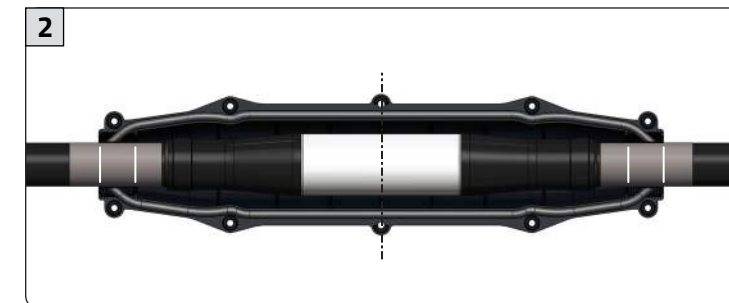

Centralize the lower shell to the connection and mark the positions for the mastic tape.

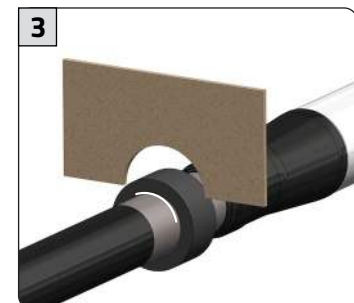

Wind the mastic tape. Check the correct size using the cardboard calliper. Make sure the optional copper braid is in between layers of tape.

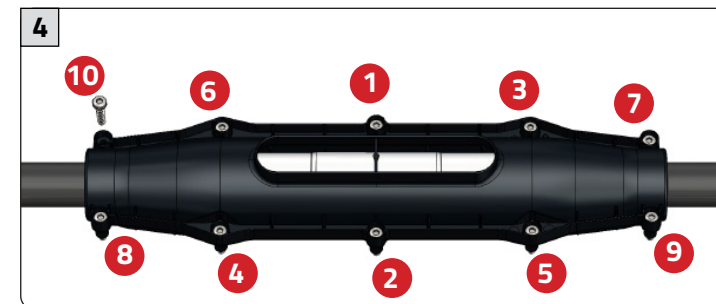

Place both shells. Assemble and tighten all screws with a 15/64" size allen key up to a torque of 3.7 ft-lb.

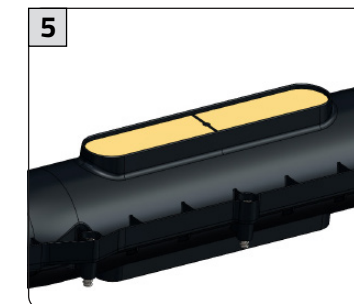

Open the Protolin® outer bag. Mix the resin according to the instructions on the bag. Fill the splice to the top of the rib in the fill opening.

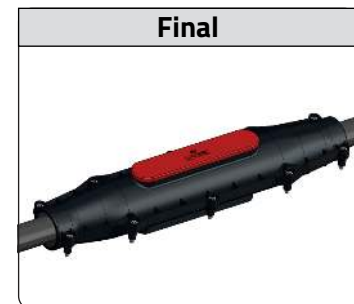

Close the fill opening with the cap. Be careful when moving the splice, the resin will stay liquid for about 45 minutes.

⚠ Put the splice into service according to the instructions of the network administrator.